

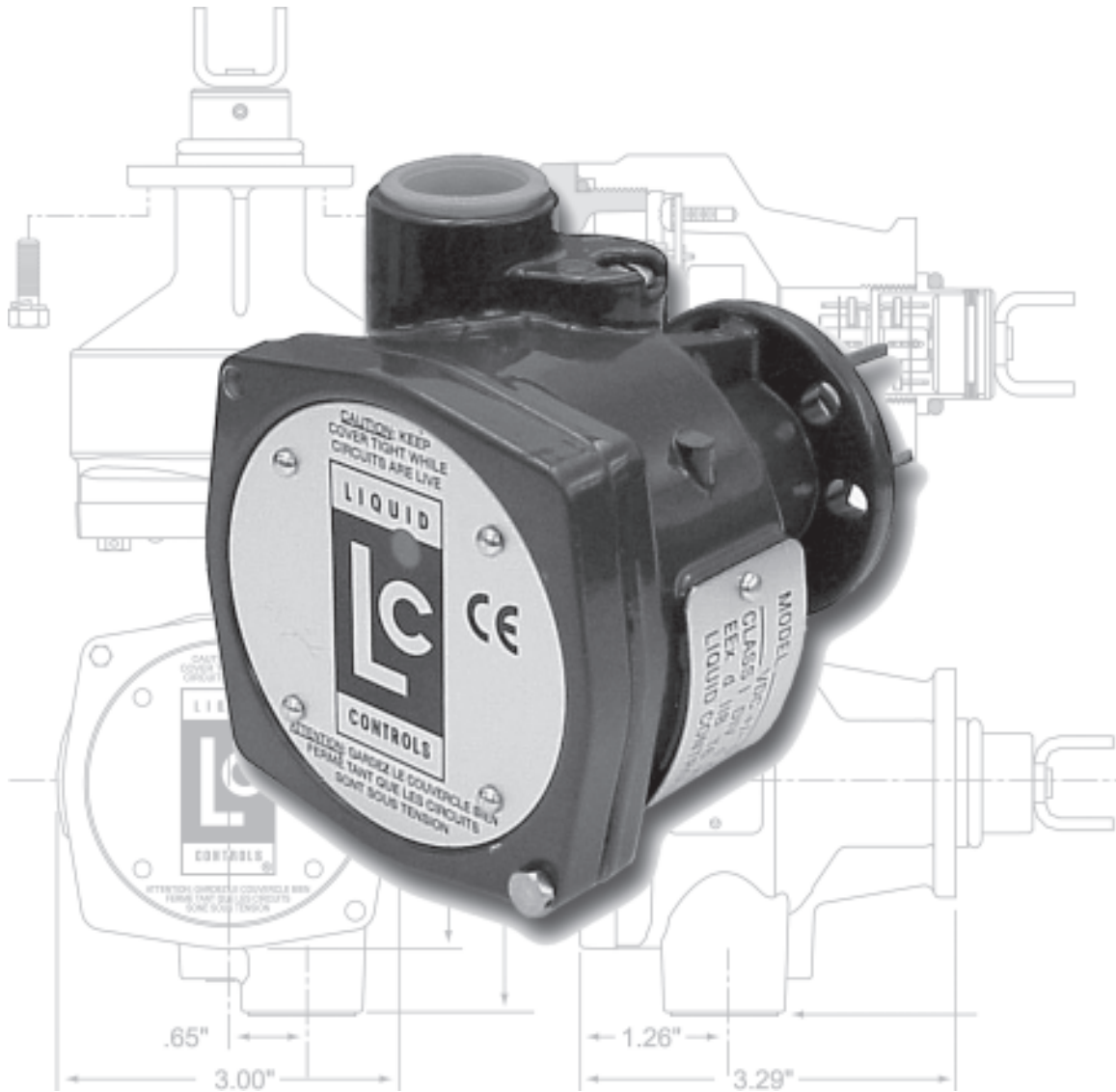

Installation & Parts Manual

Pulse Output Device (POD)

**LIQUID
CONTROLS**
A Unit of IDEX Corporation



Installation: EM300-10

www.lcmeter.com

Table of Contents

<u>Description</u>	<u>Page Number</u>	<u>Description</u>	<u>Page Number</u>
General Information	2	Installing the POD Extension	6
POD Models	2	Wiring the POD	7
Specifications	3	Wiring Diagram	8
Installation	4-8	Illustrated Parts Breakdown	9-10
Removing Existing Hardware	4	Regulatory Compliance	11
Installing the POD	5		

Publication Updates and Translations

The most current English versions of all Liquid Controls publications are available on our website, www.lcmeter.com. It is the responsibility of the Local Distributor to provide the most current version of LC Manuals, Instructions, and Specification Sheets in the required language of the country, or the language of the end user to which the products are shipping. If there are questions about the language of any LC Manuals, Instructions, or Specification Sheets, please contact your Local Distributor.

⚠ WARNING

- Before using this product, read and understand the instructions.
- Save these instructions for future reference.
- All work must be performed by qualified personnel trained in the proper application, installation, and maintenance of equipment and/or systems in accordance with all applicable codes and ordinances.
- Failure to follow the instructions set forth in this publication could result in property damage, personal injury, or death from fire and/or explosion, or other hazards that may be associated with this type of equipment.

General Information

The Liquid Controls Pulse Output Device (POD) converts the rotary motion of the Liquid Controls Positive Displacement Flowmeter into electronic pulses. This allows the meter to interface with a wide variety of electronic monitoring devices and control equipment.

The POD mounts directly to the front cover of any Liquid Controls meter in place of the packing gland. The motion of the meter's blocking rotor is magnetically coupled through a stainless steel wall to the electronics compartment of the POD. This eliminates the dynamic seal of the packing gland and isolates the electronics from the process fluid in the meter.

Inside the electronics compartment, an optical shaft encoder converts the rotary motion into a high resolution, two-channel, quadrature square wave. Both outputs are driven by field effect transistors (FETs) and switch from zero volts in the "ON" state to the user's power supply voltage in the "OFF" state. As supplied from the factory, there is a 1.0 K Ω pull-up resistor on each output which can be removed from the circuit in the field to produce a true "Open Drain" (Open Collector) output. As Open Drain devices, the outputs can sink up to 100 mA in the "ON" state and sustain up to +30 VDC in the "OFF" state.

The electronics compartment also serves as a conduit junction box. The POD has an O-Ring sealed, threaded cover. The standard wire entrance is a 1/2-14 NPT female hub which accepts threaded conduit or a cable gland. A screw-type, removable, terminal block on the circuit board facilitates wiring of the unit. With the wiring entrance sealed and the cover in place, the housing has a weatherproof rating of NEMA 4X. In addition, the housing is UL and Canadian-UL explosion-proof rated (when installed with approved conduit) and ATEX rated flame-proof (pending).

POD Models

There are five **POD** models available:

- POD1:** Fork Drive with Buna-N O-Ring, 100 PPR Quad Pulser, +8 to +24 VDC
- POD2:** Fork Drive with Teflon O-Ring, 100 PPR Quad Pulser, +8 to +24 VDC
- POD3:** Blade Drive with Buna-N O-Ring, 100 PPR Quad Pulser, +8 to +24 VDC
- POD4:** Blade Drive with Teflon O-Ring, 100 PPR Quad Pulser, +8 to +24 VDC
- POD5:** Fork Drive with Buna-N O-Ring, 100 PPR Quad Pulser, +5 VDC

Dimensions

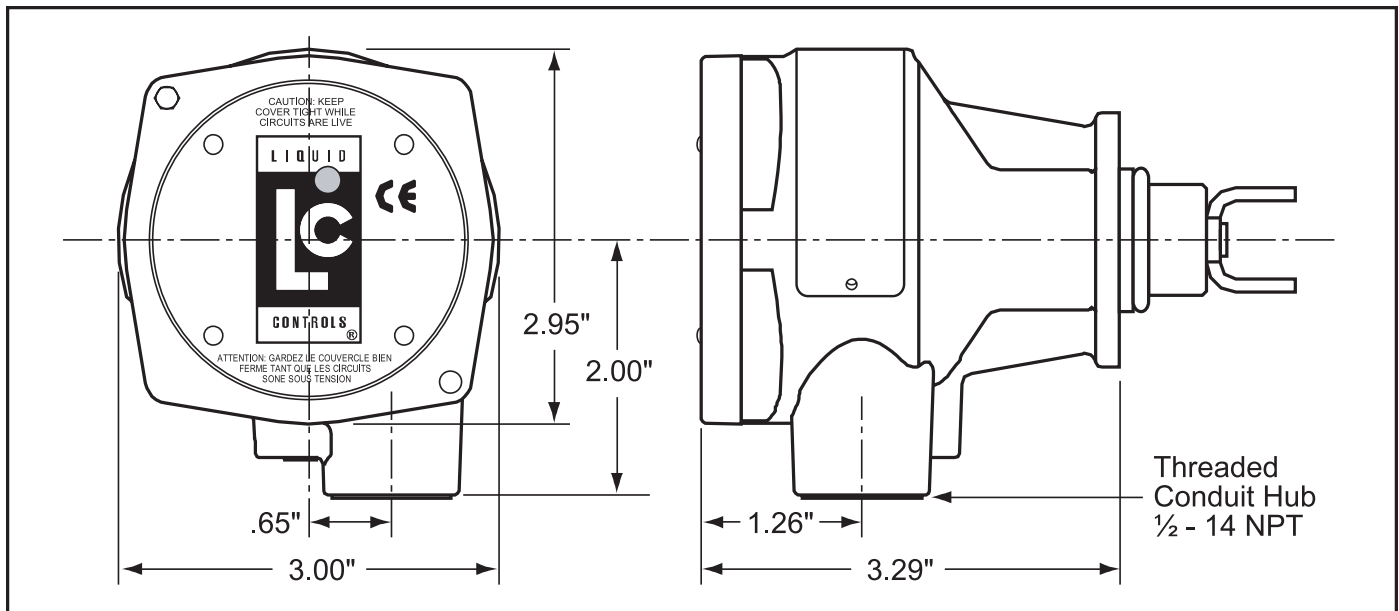

NOTE: Dimensions shown are not for construction use. Consult factory when certified Engineering Drawings are required.

- Voltage: (V+): +8 to +24 VDC (POD5 is +5 VDC) $\pm 5\%$.
- Current supply: 26 mA typical.
- Output Signal Resolution: 100 pulses per encoder revolution, unscaled. For actual meter resolution, see table below.
- Square Wave: Single or dual quadrature channel output.
- Pulse Timing: Nominal 50% on and 50% off.
- Rise/Fall Time of Pulse: $< 5 \mu s$.
- Operating Temperature Range: -40° to $+185^\circ F$ (-40° to $+85^\circ C$).
- Output: Current sinking 100 mA maximum in "ON" state; V+ supply @ 1.0 K Ω in "OFF" state. Optional Open Drain FET (Field Effect Transistor). FET rating (drain to source voltage) +30 VDC maximum.
- Humidity Range: 0-100 %, non-condensing.
- Shock: 50 G's for 10 ms.
- Vibration: 1 G at 10-150 Hz.
- Electromagnetic Compatibility (EMI, RFI, etc.): to IEC 801 Standard.
- Pulse Transmission Distance: Up to 5,000 feet (1,524 meters).
- Operates in bidirectional flow applications.

Output Signal Resolution

M & MA Series Meters	Pulses/ Gallon/ Channel	Pulses/ Litre/ Channel	Max Output - kHz
MA-4	407.9	107.8	0.27
M-5, MA-5 (3:1)	407.9	107.8	0.41
M-5, MA-5 (1:1)	1,223.7	323.4	1.22
M-7, MA-7	555.5	146.8	0.93
M-10	555.5	146.8	1.48
M-15, MA-15	205.8	54.4	0.69
M-25	205.8	54.4	0.86
M-30, M-40	74.2	19.6	0.43
M-340	74.2	19.6	0.53
M-60 (new style)	39.8	10.5	0.40
M-60 (old style)	25.5	6.7	0.26
M-80	39.8	10.5	0.53

MS Series Meters	Pulses/ Gallon/ Channel	Pulses/ Litre/ Channel	Max Output - kHz
MS-7	555.5	146.8	0.93
MS-15	205.8	54.4	0.69
MS-25	205.8	54.4	0.86
MS-30	74.2	19.6	0.43
MS-40	74.2	19.6	0.53
MS-75	25.5	6.7	0.30
MS-120	15.8	4.2	0.26

Installation

New Installations

When ordered with the flowmeter, the POD comes factory installed on the meter and ready for wiring. Refer to the detailed wiring information which begins on Page 7.



POD Installed on meter.

⚠WARNING

Before disassembly of any meter or accessory component, **ALL INTERNAL PRESSURES MUST BE RELIEVED AND ALL LIQUID DRAINED FROM THE SYSTEM IN ACCORDANCE WITH ALL APPLICABLE PROCEDURES.** Pressure must be 0 (zero) psi. Close all liquid and vapor lines between the meter and liquid source.

For **Safety Rules Regarding LPG**, refer to **NFPA Pamphlet 58** and local authorities.

Failure to follow this warning could result in property damage, personal injury, or death from fire and/or explosion, or other hazards that may be associated with this type of equipment.

Retrofit Installations

Removing Existing Hardware

1. **Relieve the pressure** from the process piping to the meter.
2. **Drain** the meter by opening the meter's drain plugs.
3. Remove the mechanical counter, adjuster, and adjuster drive shaft from the front of the meter.
4. Some meters have a counter adapter bracket which is bolted on. If this is the case, remove the counter bracket by removing the bolts that hold it in place. If the counter adapter bracket is integral to the meter, it cannot be removed. In this case, one of four POD Pulsar Extensions will be required.

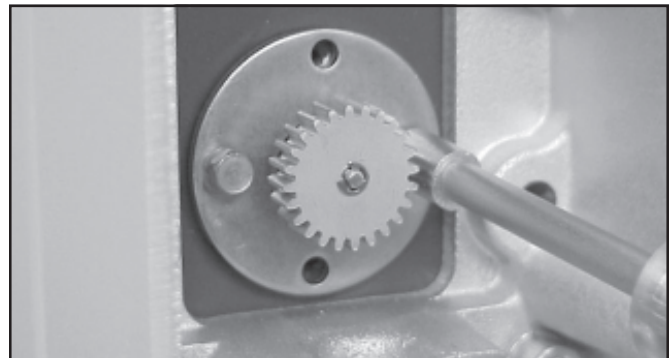

Remove Packing Gland Mounting Screws

NOTE: Ensure there is no pressure inside the flowmeter before attempting to remove the packing gland. **LINE PRESSURE MUST BE 0.0 PSI.**

5. Remove the packing gland mounting screws. Pull the packing gland out of the meter. If the O-Ring does not come out with the packing gland, be sure to remove it from the packing gland well before installing the POD.



Packing Gland Removed

When this is complete, the POD can be installed.

Installing the POD

1. Verify that the proper POD Model was obtained by comparing the driver tang on the POD to the driver tang on the packing gland that was removed in Step 5 of **Removing Existing Hardware** on Page 4. There are two types of packing gland/POD driver tangs: **blade** type and **fork** type. Blade type packing glands must be replaced with blade type PODs. Fork type packing glands must be replaced with fork type PODs.
2. Determine the desired orientation of the conduit hub. The hub can be positioned in one of eight possible orientations as shown in the figure to the right.

NOTE: Meters with only two packing gland mounting screws are limited to four orientations.

NOTE: When using a cable gland to seal the wire entrance, any of the eight orientations can be used. However, when using conduit, the hub should face down so moisture that may accumulate in the conduit will drain away from the POD electronics.

3. Position the O-Ring over the bottom of the POD as shown to the right.
4. Align the fork style or blade style driver with the drive mechanism in the meter and guide the POD into the opening in the meter cover. When properly aligned, the POD will go in until its mounting flange abuts the meter cover.
5. Rotate the POD to the desired orientation and thread in the mounting screws until they are snug. Using a 7/32" box end wrench, tighten the screws and torque them to 21-25 inch-pounds.
6. Proceed to Page 7 for wiring instructions.

NOTE: If a POD Extension Kit is required, it must be installed prior to installation of the POD. This is addressed on Page 6.

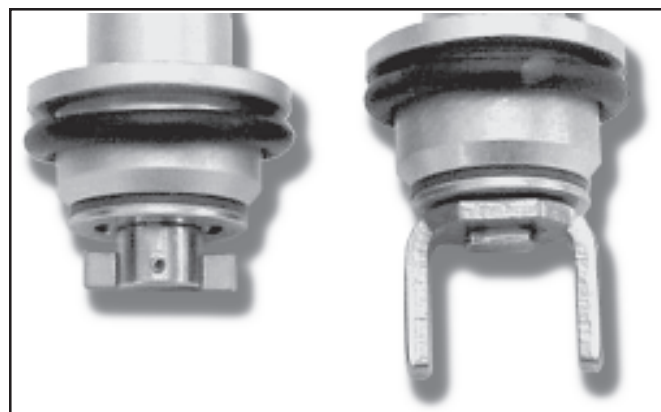

Blade Style Tang (Left) and Fork Style Tang (Right)

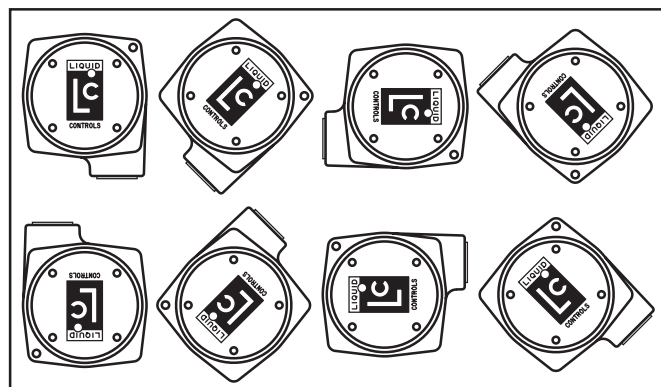

POD Conduit Hub Orientations

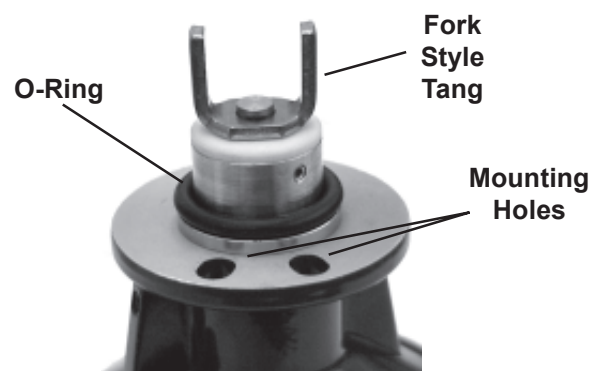

O-Ring Position & Mounting Holes

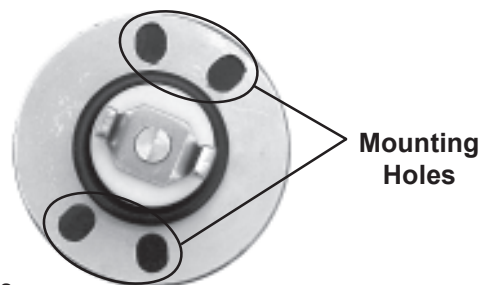

Mounting Holes

Installation

Installing the POD Extension

The POD Extension is used when the meter has an integral counter adapter bracket or for high temperature applications. The POD Extension is used to extend the connection away from the meter.

There are four POD Extension models available.

49754: Fork Drive with Buna-N O-Ring
(Use with POD1 or POD5)

49756: Fork Drive with Teflon O-Ring
(Use with POD2)

49757: Blade Drive with Buna-N O-Ring
(Use with POD1 or POD5)

49759: Blade Drive with Teflon O-Ring
(Use with POD2)

NOTE: Regardless of the POD Extension being used, the POD Pulser must be a FORK drive pulser.

Once the existing hardware has been removed as described on Page 4, the POD Extension can be installed.

1. Verify that the proper POD Extension Model was obtained by comparing the driver tang on the POD Extension to the driver tang on the packing gland that was removed in Step 5 of **Removing Existing Hardware** on Page 4. There are two types of Packing Gland/POD Extension driver tangs: **blade** type and **fork** type. Blade type packing glands must be replaced with blade type POD Extensions. Fork type packing glands must be replaced with fork type POD Extensions.
2. Install the POD Extension using the two screws provided. There are two sets of holes in the POD Extension for these screws; one set is 1.625" apart and the other is 1.5" apart. Line up the holes with the meter to determine which set to use. Tighten the screws and torque them to 21-25 inch-pounds.
3. Once the POD Extension is in place, the POD may be installed onto the POD Extension. Align the POD Fork Tang with the internal POD Extension Driver. Use the two screws provided to mount the POD to the POD Extension using two of the tapped holes in the POD Extension. Using a 7/32" box end wrench, tighten the screws and torque them to 21-25 inch-pounds.
4. Proceed to Page 7 for wiring instructions.

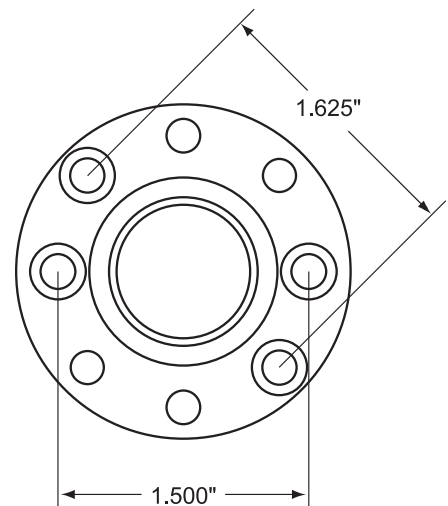

Pod Extension Driver



Wiring the POD

Wiring Conduit System

When wiring the POD, the wires must enter through the POD's conduit hub. For explosion proof rated systems (Class I, Div 1.), the wiring must be in rigid conduit that is rated for explosion proof installation. The conduit must be engaged five (5) full threads into the female hub on the POD to meet explosion proof requirements.

When installing in a Division 2 location, use either rigid conduit, flexible conduit, or no conduit. When no conduit is used, the instrument cable must be brought into the POD conduit hub using a cable gland to seal the wiring to maintain the Enclosure NEMA 4X rating. Regardless of the type of connection used, thread sealant should be applied to prevent moisture from getting into the POD electrical housing.

NOTE: For North American installations, the installation must be fully in accordance with the National Electrical Code (US) or the Canadian Electrical Code respectively to maintain the hazardous location ratings on the product. This may involve using rigid conduit for all connections.

For European installations, the installation must be fully in accordance with EN 60079-14 to maintain the hazardous location ratings on the product. This may involve using special cable glands for all connections.

Wiring Cable

Multi-wire cable with an overall shield is recommended for POD wiring. Use individual wires between 16 and 20 AWG or shielded cable no less than 22 AWG. Cable runs up to 5000 ft (1524 m) are possible, however cable runs over 1000 ft (304.8 m) should use lower AWG wire to reduce the IR voltage drop and the inter-wire capacitance. In addition, long runs may require a lower value pull-up resistor due to the additional cable capacitance that the pulser must drive. Cable that has a metalized foil plastic shield with a drain wire is recommended over cable with woven shields because it is easier to terminate the drain wire type cable.

Terminal Block

Removing the cover of the POD will expose a 4 position terminal block for connection to the user's electrical system. The terminal block can be unplugged from the board for ease of wiring. Pull it straight up to remove.

The terminal block screws require a straight blade screwdriver with a tip less than 1/8" wide. Before inserting wires into the terminal block, strip 1/4" of insulation off each wire. Turn each terminal screw counterclockwise a few turns to make sure that the wiring slot is fully open to accept wire. Insert the stripped end of the wire and tighten the terminal block screw.

Plug the terminal block back into the board if it was removed. Be sure it is properly oriented with the four pins.

Wiring Configurations

The wiring configuration used depends on the system needs. The POD can be wired using only one of the two channels (Channel A or B) if the flowmeter has flow in only one direction. To detect both forward and reverse flow, both channels, which are in quadrature to each other, must be used. Channel A will lead Channel B by 90° in one flow direction and Channel B will lead Channel A in the reverse direction. Quadrature is required in most Weights & Measures approved installations.

Conversion to Open Drain Output

As supplied by the factory, the POD has a 1.0 KΩ pull-up resistor to the positive power supply on each output transistor. The unit can be modified in the field to provide true Open Drain (Open Collector) outputs if desired. To modify the POD to Open Drain outputs, follow these steps.

1. Turn off power to the unit and remove the cover by turning it counterclockwise.
2. Loosen the three circuit board mounting screws using a Philips screwdriver. Remove the entire circuit board assembly from the POD housing.
3. Clip out R1 and R2 using a sharp, diagonal cutter.
4. Reassemble the unit.

Signal Output

The diagram below shows the voltage output for a clockwise rotation of the Pulse Output Device (POD) with Channel A leading Channel B. For reverse flow applications (counterclockwise) Channel B leads Channel A.

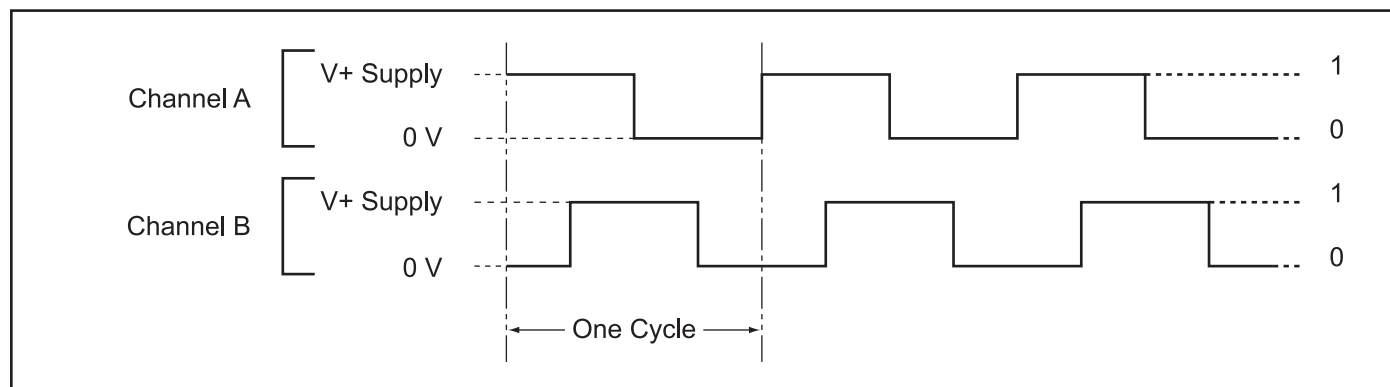

Wiring Diagrams

(For PODs with Serial Number 04-24531 and higher)

Single Channel Applications (405LR/414LR, LC202, IT400)

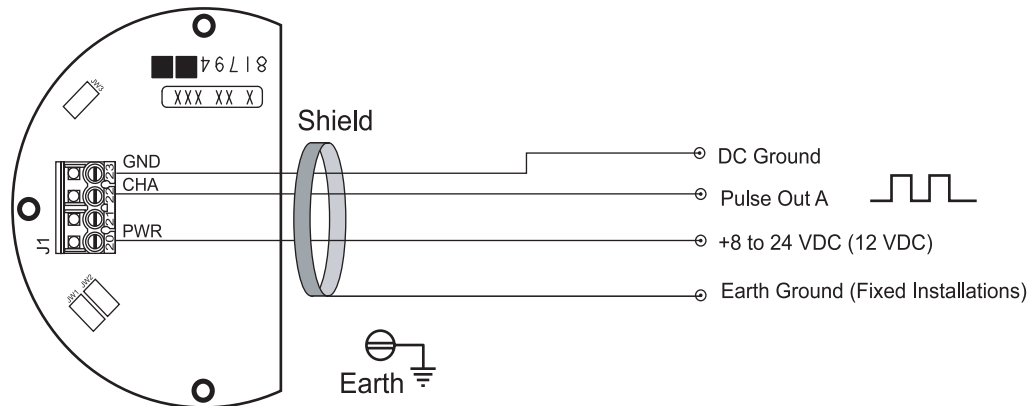

Description	POD: J1 Terminal	405LR/414LR Terminal
Power	20	11 (+12 VDC)
Channel A or B	21 or 22	9
Ground	23	12
Shield Wire	No Connection	Earth Ground Screw

Dual Channel Quadrature Applications (LectroCount® LCR®, LCR-II®, & LC³)

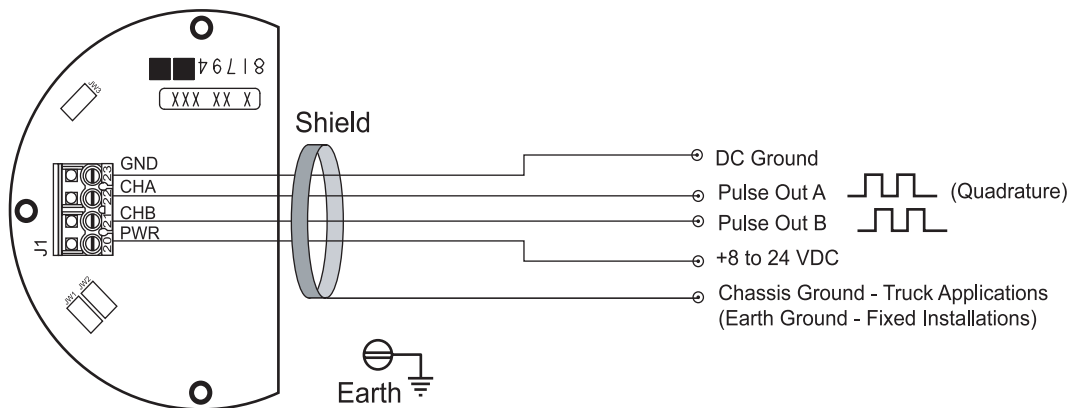

Description	POD: J1 Terminal	LCR, LCR-II™: J8	LC³: J3
Power	20	31	19
Channel B	21	34	17
Channel A	22	33	18
Ground	23	38	15
Shield Wire	No Connection	J6-13	14

Wiring Information

- 1 Use metallic conduit with individual wires or use 3 conductor, 22 AWG, shielded cable.
- 2 Strip 1½" off of outer sheathing. Remove exposed shield and drain wire and then tape.
- 3 Strip ¼" insulation from each conductor and connect to the terminal blocks.

Illustrated Parts Breakdown

POD Assemblies

Item No.	Description	Part No.
4	Screw, #10-24 x .625	09079
5	Screw, #10-24 x .625	40107
8	Screw, #8-32 x .625	08192

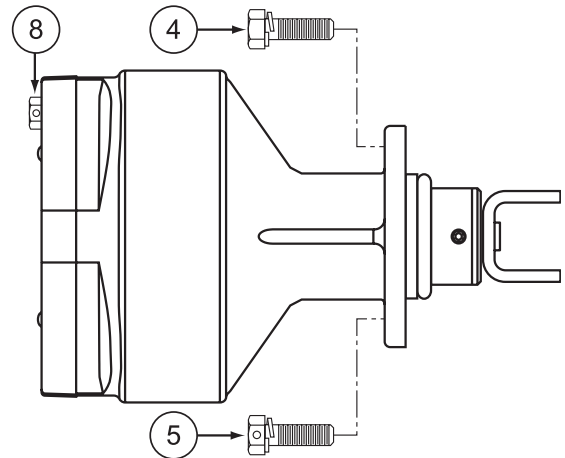

POD Internal Components

Item No.	Description	Part No.
1	PC Board Assembly	(See Below)
2	Cover Assembly	
3	Housing Assembly	
4	Drive Assembly	
5	Screw #10-24 x .625	
6	Hub Magnet Assembly	
7	O-Ring, Buna-N	
8	Screw, #5-40 x .125	
9	O-Ring, Buna-N or Teflon	
10	Screw, #6-32 x .375	
11	Hub Magnet Assembly	

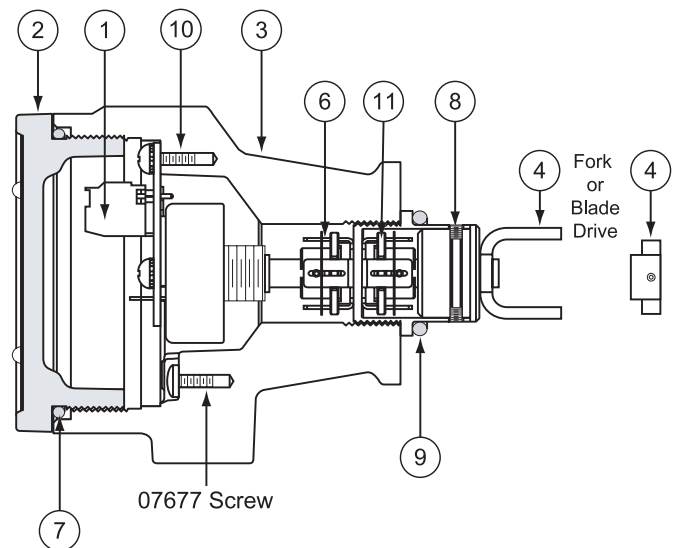

Model No.	POD1	POD2	POD3	POD4	POD5
Item No.	Part No.				
1	81794	81794	81794	81794	817941
2	81164	81164	81164	81164	81164
3	N/S*	N/S	N/S	N/S	N/S
4	81165	81165	81172	81172	81165
6	N/S	N/S	N/S	N/S	N/S
7	09212	09212	09212	09212	09212
8	09211	09211	09211	09211	09211
9	06856	09151	06856	09151	06856
10	08177	08177	08177	08177	08177
11	81159	81159	81159	81159	501241

*N/S = Not for Sale

Illustrated Parts Breakdown

POD Extension

Models 49754 & 49756

<u>Item No.</u>	<u>Description</u>	<u>Part No.</u>
1	Pulser Extension Driver	N/S*
2	Pulser Housing	N/S
3	Screw, #10-24 x 2.00	09228
4	Dowel Pin	N/S
5	O-Ring, Buna-N (49754)	06856
	O-Ring, Teflon (49756)	09151
6	Mag Bearing	N/S
7	Fork Driver	48282
8	Fork Drive Shaft	N/S

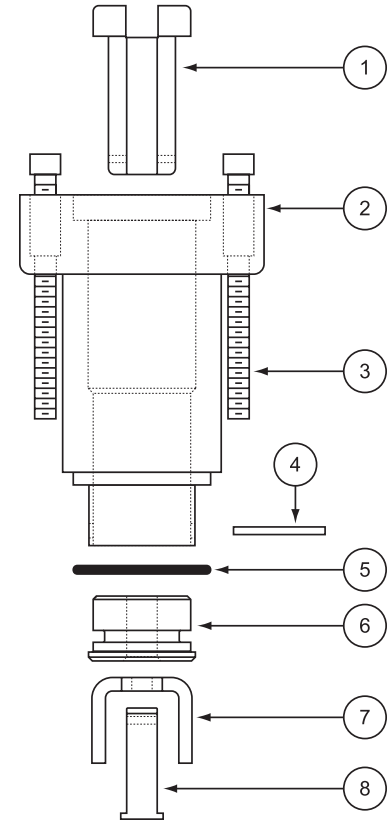



POD Extension

Models 49757 & 49759

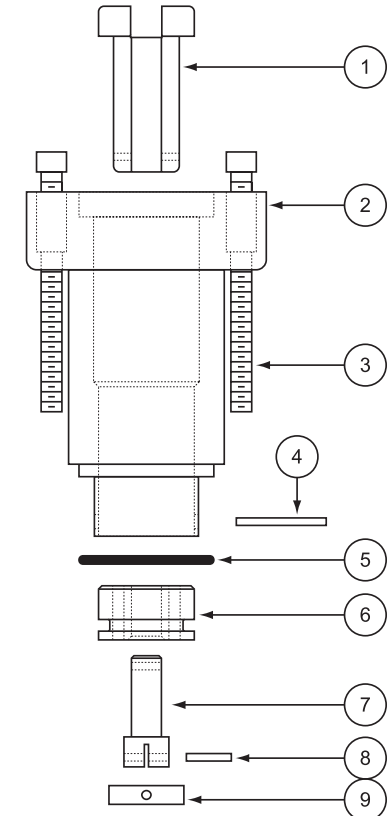
<u>Item No.</u>	<u>Description</u>	<u>Part No.</u>
1	Pulser Extension Driver	N/S
2	Pulser Housing	N/S
3	Screw, #10-24 x 2.00	09228
4	Dowel Pin	N/S
5	O-Ring, Buna-N (49757)	06856
	O-Ring, Teflon (49759)	09151
6	Mag Bearing	N/S
7	Blade Driver	N/S
8	Roll Pin	06051
9	Drive Blade	40812



*N/S = Not for Sale

LIQUID CONTROLS LAKE BLUFF, IL USA	CLASS I DIV 1 & 2 GROUP C & D
MODEL _____ SERIAL NO. _____	ENCL TYPE 4X
○ YEAR OF MFR. _____ VDC +/-5%, 30 mA MAX.	Telemetering Equipment For Use in Hazardous Locations ○
 EEx d IIB T6 LCIE04ATEX6033 II 2 G 	DO NOT OPEN WHILE ENERGIZED
	 Listed 2P46



This equipment has been evaluated to the Equipment For Potentially Explosive Atmospheres Directive, 94/9/EC

II:

... and is found to be suitable for use in surface (not mine) installations

2 G:

... where a high level of protection is provided against flammable gases, vapors, or liquids, which may exist during normal operation.

d:

Protection is provided by a flameproof enclosure

IIB:

... for "B" gases, such as propane.

T6:

Temperature code for ATEX surface temperature limitations. $T6 \leq 85^{\circ}\text{C}$

LCIE04ATEX6033:

Evaluation was made by LCIE in France.



Evaluated by UL to both the Canadian and US requirements for explosion proof products intended for use in Class I, Division 1, Groups C & D environments as classified by the US and/or Canadian Electrical Code.

Type 4X:

Either indoor or outdoor use to provide a degree of protection against falling rain, splashing water, and hose-directed water; undamaged by the formation of ice on the enclosure; resists corrosion.

LIQUID CONTROLS GROUP

IDEAL SOLUTIONS INTEGRATED SYSTEMS

LIQUID CONTROLS EUROPE • LIQUID CONTROLS SPONSLER

LIQUID CONTROLS • LIQUID CONTROLS INDIA

FAURE HERMAN • TOPTECH SYSTEMS

CORKEN • SAMPI



LIQUID CONTROLS

105 Albrecht Drive
Lake Bluff, IL 60044
(847) 2951050

TOPTECH SYSTEMS

280 Hunt Park Cove
Longwood, FL 32750
(407) 332-1774

CORKEN

3805 Northwest 36th St.
Oklahoma City, OK 73112
(405) 946-5576

LIQUID CONTROLS EUROPE/SAMPI

Via Amerigo Vespucci 1
55011 Altopascio (Lucca), Italy
+39 (0) 583 247600

Nateus Business Park
Nieuwe Weg 1-Haven 1053
B-2070 Zwijndrecht (Antwerp), Belgium
+32 (0)3 250 60 60

LIQUID CONTROLS INDIA

808 VCCI Complex
Gidc Makarpura
Vadodara-390 101
Gujarat, India
+91 265 2631855

FAURE HERMAN

Route de Bonnetable
B.P. 20154
72406 La Ferté-Bernard Cedex, France
+33 (0) 243 0602860

6961 Brookhollow West Drive
Houston, TX 77040
(713) 623-0808

LIQUID CONTROLS SPONSLER

2363 Sandifer Boulevard
Westminster, SC 29693
(864) 647-2065



LIQUID CONTROLS

A Unit of IDEX Corporation
105 Albrecht Drive
Lake Bluff, IL 60044-2242
1.800.458.5262 • 847.295.1050
Fax: 847.295.1057
www.lcmeter.com

© 2007 Liquid Controls
Pub. No. 500003A
(07/20/07)



CERTIFICATED FIRM
Certificate No. 08732



CERTIFICATED FIRM
Certificate No. 05049